

## Lecture Note – 17

### PRESTRESS CONCRETE

**Code: IS1343: 1980**

#### **Introduction:**

##### **Definition of Prestress:**

Prestress is defined as a method of applying pre-compression to control the stresses resulting due to external loads below the neutral axis of the beam tension developed due to external load which is more than the permissible limits of the plain concrete. The pre-compression applied (may be axial or eccentric) will induce the compressive stress below the neutral axis or as a whole of the beam c/s. Resulting either no tension or compression.

##### **Basic Concept**

Prestressed concrete is basically concrete in which internal stresses of a suitable magnitude and distribution are introduced so that the stresses resulting from the external loads are counteracted to a desired degree.

##### **Terminology**

1. **Tendon:** A stretched element used in a concrete member of structure to impart prestress to the concrete.
2. **Anchorage:** A device generally used to enable the tendon to impart and maintain prestress in concrete.
3. **Pretensioning:** A method of prestressing concrete in which the tendons are tensioned before the concrete is placed. In this method, the concrete is introduced by bond between steel & concrete.
4. **Post-tensioning:** A method of prestressing concrete by tensioning the tendons against hardened concrete. In this method, the prestress is imparted to concrete by bearing.

##### **Materials for prestress concrete members:**

1. **Cement:** The cement used should be any of the following
  - (a) Ordinary Portland cement conforming to IS269
  - (b) Portland slag cement conforming to IS455. But the slag content should not be more than 50%.
  - (c) Rapid hardening Portland cement conforming to IS8041.
  - (d) High strength ordinary Portland cement conforming to IS8112.

- 2. Concrete:** Prestress concrete requires concrete, which has a high compressive strength reasonably early age with comparatively higher tensile strength than ordinary concrete. The concrete for the members shall be air-entrained concrete composed of Portland cement, fine and coarse aggregates, admixtures and water. The air-entraining feature may be obtained by the use of either air-entraining Portland cement or an approved air-entraining admixture. The entrained air content shall be not less than 4 percent or more than 6 percent.

Minimum cement content of 300 to 360 kg/m<sup>3</sup> is prescribed for the durability requirement.

The water content should be as low as possible.

- 3. Steel:-** High tensile steel , tendons , strands or cables

The steel used in prestress shall be any one of the following:-

- (a) Plain hard-drawn steel wire conforming to IS1785 (Part-I & Part-III)
- (b) Cold drawn indented wire conforming to IS6003
- (c) High tensile steel wire bar conforming to IS2090
- (d) Uncoated stress relived strand conforming to IS6006

High strength steel contains:

- 0.7 to 0.8% carbons,
- 0.6% manganese,
- 0.1% silica

### **Durability, Fire Resistance & Cover Requirements For P.S.C Members:-**

According to IS: 1343-1980

20 mm cover for pretensioned members

30 mm or size of the cable which ever is bigger for post tensioned members.

If the prestress members are exposed to an aggressive environment, these covers are increased by another 10 mm.

### **Necessity of high grade of concrete & steel:**

Higher the grade of concrete higher the bond strength which is vital in pretensioned concrete, Also higher bearing strength which is vital in post-tensioned concrete. Further creep & shrinkage losses are minimum with high-grade concrete.

Generally minimum M30 grade concrete is used for post-tensioned & M40 grade concrete is used for pretensioned members.

The losses in prestress members due to various reasons are generally in the range of  $250 \text{ N/mm}^2$  to  $400 \text{ N/mm}^2$ . If mild steel or deformed steel is used the residual stresses after losses is either zero or negligible. Hence high tensile steel wires are used which varies from 1600 to  $2000 \text{ N/mm}^2$ .

### **Advantage of Prestressed Concrete**

1. The use of high strength concrete and steel in prestressed members results in lighter and slender members than is possible with RC members.
2. In fully prestressed members the member is free from tensile stresses under working loads, thus whole of the section is effective.
3. In prestressed members, dead loads may be counter-balanced by eccentric prestressing.
4. Prestressed concrete member posses better resistance to shear forces due to effect of compressive stresses presence or eccentric cable profile.
5. Use of high strength concrete and freedom from cracks, contribute to improve durability under aggressive environmental conditions.
6. Long span structures are possible so that saving in weight is significant & thus it will be economic.
7. Factory products are possible.
8. Prestressed members are tested before use.
9. Prestressed concrete structure deflects appreciably before ultimate failure, thus giving ample warning before collapse.
10. Fatigue strength is better due to small variations in prestressing steel, recommended to dynamically loaded structures.

### **Disadvantages of Prestressed Concrete**

1. The availability of experienced builders is scanty.
2. Initial equipment cost is very high.
3. Availability of experienced engineers is scanty.
4. Prestressed sections are brittle
5. Prestressed concrete sections are less fire resistant.

### **Classifications and Types**

Prestressed concrete structures can be classified in a number of ways depending upon the feature of designs and constructions.

1. **Pre-tensioning**: In which the tendons are tensioned before the concrete is placed, tendons are temporarily anchored and tensioned and the prestress is transferred to the concrete after it is hardened.

2. Post-tensioning: In which the tendon is tensioned after concrete has hardened. Tendons are placed in sheathing at suitable places in the member before casting and later after hardening of concrete.

The various methods by which pre-compression are imparted to concrete are classified as follows:

1. Generation of compressive force between the structural elements and its abutments using flat jack.
2. Development of hoop compression in cylindrically shaped structures by circumferential wire binding.
3. Use of longitudinally tensioned steel embedded in concrete or housed in ducts.
4. Use of principle of distortion of a statically indeterminate structure either by displacement or by rotation of one part relative to the remainder.
5. Use of deflected structural steel sections embedded in concrete until the hardening of the latter.
6. Development of limited tension in steel and compression in concrete by using expanding cements.

The most widely used method for prestressing of structural concrete elements is longitudinal tensioning of steel by different tensioning devices. Prestressing by the application of direct forces between abutments is generally used for arches and pavements, while flat jacks are invariably used to impart the desired forces.

### **Tensioning Devices**

The various types devices used for tensioning steel are grouped under four principal categories, viz.

1. Mechanical devices: The mechanical devices generally used include weights with or without lever transmission, geared transmission in conjunction with pulley blocks, screw jacks with or without gear devices and wire-winding machines. These devices are employed mainly for prestressing structural concrete components produced on a mass scale in factory.
2. Hydraulic devices: These are simplest means for producing large prestressing force, extensively used as tensioning devices.
3. Electrical devices: The wires are electrically heated and anchored before placing concrete in the mould. This method is often referred to as thermo-prestressing and used for tensioning of steel wires and deformed bars.
4. Chemical devices: Expanding cements are used and the degree of expansion is controlled by varying the curing condition. Since the expansive action of cement

while setting is restrained, it induces tensile forces in tendons and compressive stresses in concrete.

### Prestressing System:

#### 1. Pretensioning system:

In the pre-tensioning systems, the tendons are first tensioned between rigid anchor-blocks cast on the ground or in a column or unit –mould types pretensioning bed, prior to the casting of concrete in the mould. The tendons comprising individual wires or strands are stretched with constant eccentricity or a variable eccentricity with tendon anchorage at one end and jacks at the other. With the forms in place, the concrete is cast around the stressed tendon. The system is shown in Fig. 1 below.

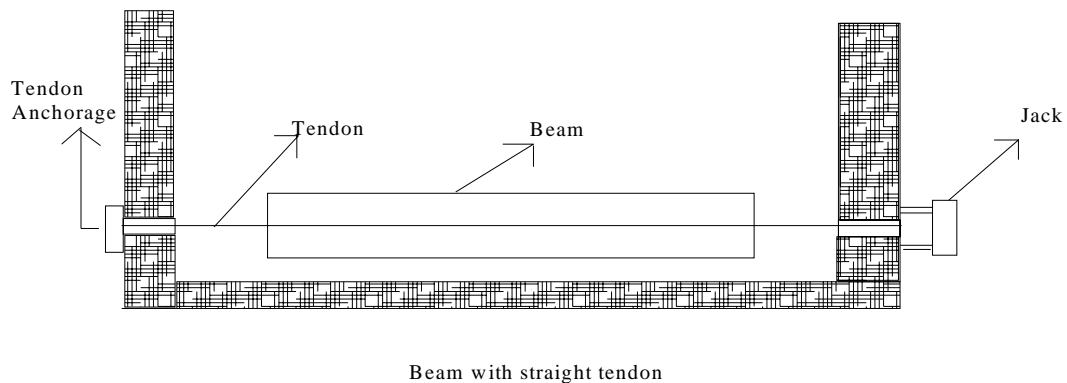

**Fig. 1 Prestressing system**

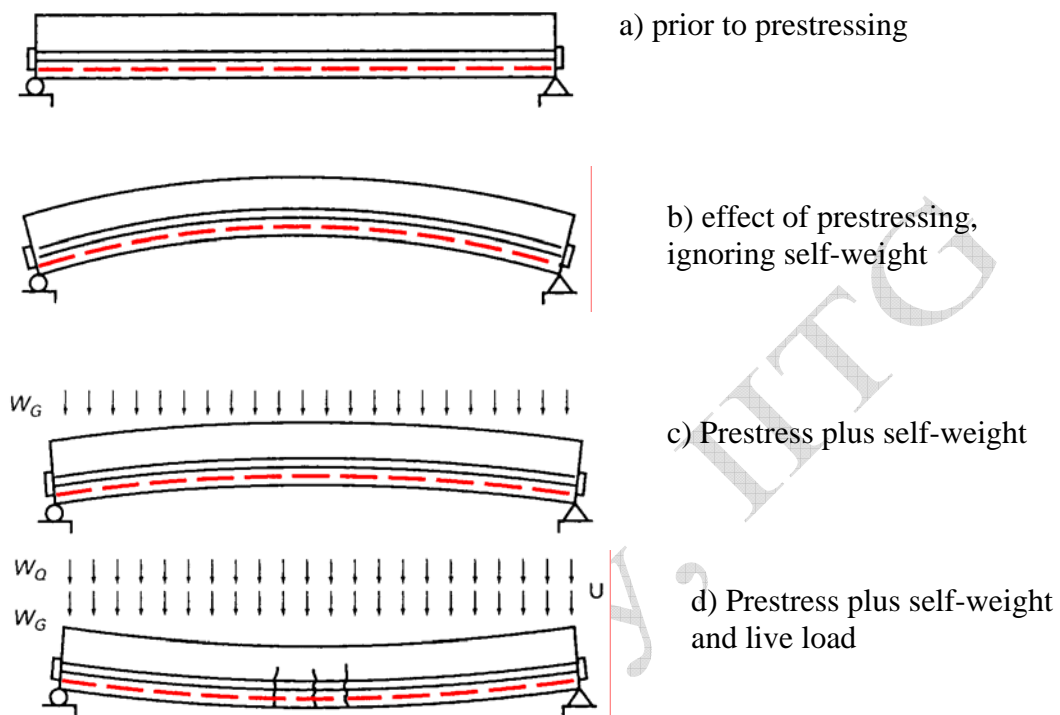

**Fig. 2 Effect of load during Prestressing**

## 2. Post-tensioned system:

In post-tensioning the concrete unit are first cast by incorporating ducts or grooves to house the tendons. When the concrete attains sufficient strength, the high-tensile wires are tensioned by means of jack bearing on the end of the face of the member and anchored by wedge or nuts. The forces are transmitted to the concrete by means of end anchorage and, when the cable is curved, through the radial pressure between the cable and the duct. The space between the tendons and the duct is generally grouted after the tensioning operation.

Most of the commercially patented prestressing systems are based on the following principle of anchoring the tendons:

1. Wedge action producing a frictional grip on the wire.
2. Direct bearing from the rivet or bolt heads formed at the end of the wire.
3. Looping the wire around the concrete.

**Methods:**

1. Freyssinet system
2. Gifford-Udall system
3. Magnel blaton system
4. Lee-McCall system

**Differences of Prestressed Concrete Over Reinforced Concrete:**

1. In prestress concrete member steel plays active role. The stress in steel prevails whether external load is there or not. But in R.C.C., steel plays a passive role. The stress in steel in R.C.C members depends upon the external loads. *i.e.*, no external load, no stress in steel.
2. In prestress concrete the stresses in steel is almost constant where as in R.C.C the stress in steel is variable with the lever arm.
3. Prestress concrete has more shear resistance, where as shear resistance of R.C.C is less.
4. In prestress concrete members, deflections are less because the eccentric prestressing force will induce couple which will cause upward deflections, where as in R.C.C., deflections are more.
5. In prestress concrete fatigue resistance is more compare to R.C.C. because in R.C.C. stress in steel is external load dependent where as in P.S.C member it is load independent.
6. Prestress concrete is more durable as high grade of concrete is used which are more dense in nature. R.C.C. is less durable.
7. In prestress concrete dimensions are less because external stresses are counterbalance by the internal stress induced by prestress. Therefore reactions on column & footing are less as a whole the quantity of concrete is reduced by 30% and steel reduced by about 60 to 70%. R.C.C. is uneconomical for long span because in R.C.C. dimension of sections are large requiring more concrete & steel. Moreover as self-weight increases more reactions acted on columns & footings, which requires higher sizes.

### Comparative Study: Pretension Vs Post-tensioned Member

Pretension member	Post-tensioned member
1. In pretensioned prestress concrete, steel is tensioned prior to that of concrete. It is released once the concrete is placed and hardened. The stresses are transferred all along the wire by means of <b>bond</b> .	1. Concreting is done first then wires are tensioned and anchored at ends. The stress transfer is by <b>end bearing</b> not by bond.
2. Suitable for short span and precast products like sleepers, electric poles on mass production.	2. Suitable for long span bridges
3. In pretensioning the cables are basically straight and horizontal. Placing them in curved or inclined position is difficult. However the wire's can be kept with eccentricity. Since cables can not be aligned similar to B.M.D. structural advantages are less compare to that of post-tensioned.	3. The post tensioning cables can be aligned in any manner to suit the B.M.D due to external load system. Therefore it is more economical particularly for long span bridges. The curved or inclined cables can have vertical component at ends. These components will reduce the design shear force. Hence post-tensioned beams are superior to pretensioned beams both from flexural and shear resistances point.
4. Prestress losses are more compare to that of post-tensioned concrete.	4. Losses are less compare to pre-tensioned concrete



## Lecture Note – 18

### Analysis of Prestress Member

#### Basic assumption

1. Concrete is a homogenous material.
2. Within the range of working stress, both concrete & steel behave elastically, notwithstanding the small amount of creep, which occurs in both the materials under the sustained loading.
3. A plane section before bending is assumed to remain plane even after bending, which implies a linear strain distribution across the depth of the member.

#### Analysis of prestress member

The stress due to prestressing alone are generally combined stresses due to the action of direct load bending from an eccentrically applied load. The following notations and sign conventions are used for the analysis of prestress members.

$P$  → Prestressing force (Positive when compressive)

$e$  → Eccentricity of prestressing force

$M = Pe$  → Moment

$A$  → Cross-sectional area of the concrete member

$I$  → Second moment of area of the section about its centroid

$Z_t, Z_b$  → Section modulus of the top & bottom fibre respectively

$f_{top}, f_{bot}$  → Prestress in concrete developed at the top & bottom fibres

$y_t, y_b$  → Distance of the top & bottom fibre from the centroid of the section

$r$  → Radius of gyration

#### **(i) Concentric tendon**

In this case, the load is applied concentrically and a compressive stress of magnitude  $(P/A)$  will act through out the section. Thus the stress will generate in the section as shown in the figure below.

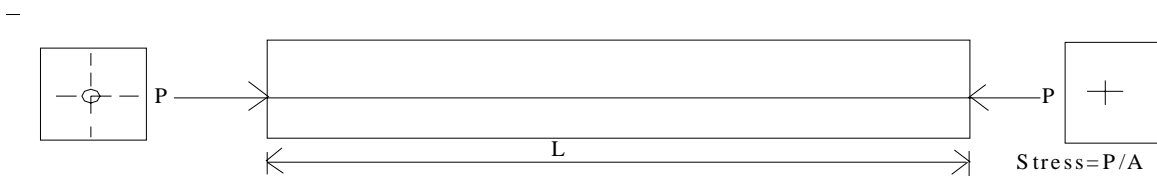

Concentric prestressing

**(ii) Eccentric tendon**

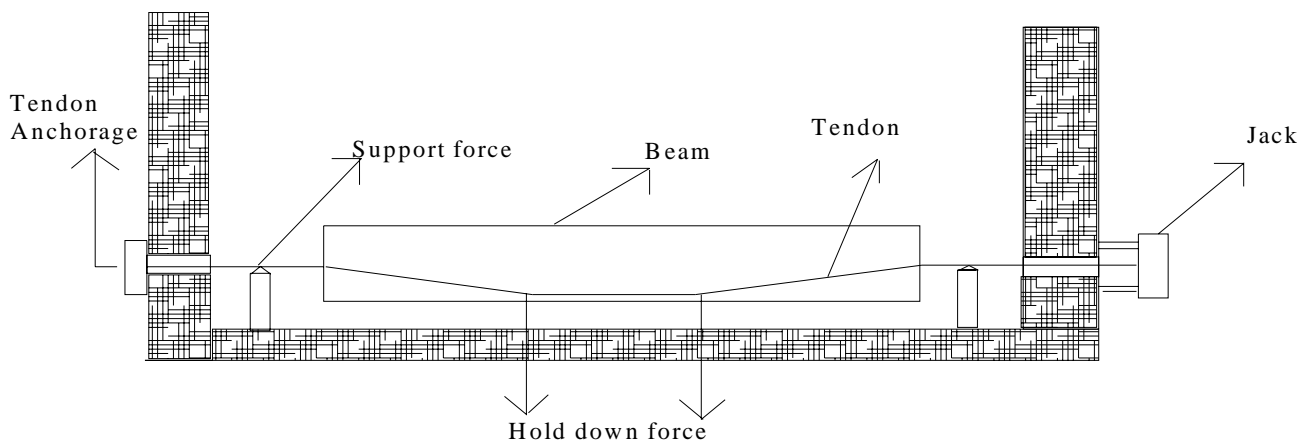

Beam with bend tendon

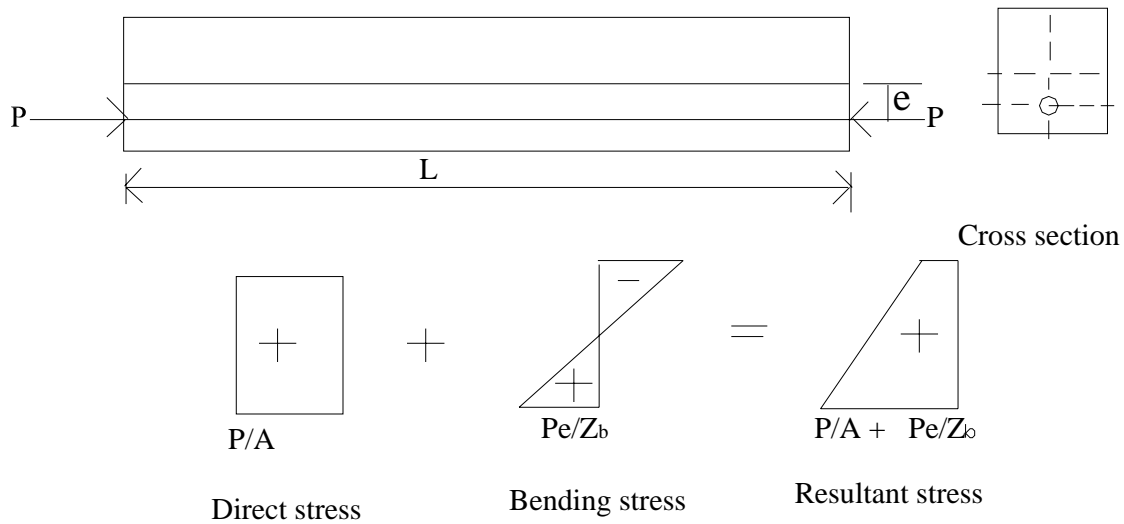

**Fig. Stress distribution for eccentric prestressing**

Thus the stresses developed at the top & bottom fibres of the beam can be written as:

$$f_{bot} = \left( \frac{P}{A} + \frac{Pe}{Z_b} \right) = \frac{P}{A} \left( 1 + \frac{ey_b}{r^2} \right); \quad f_{top} = \left( \frac{P}{A} - \frac{Pe}{Z_t} \right) = \frac{P}{A} \left( 1 - \frac{ey_t}{r^2} \right)$$

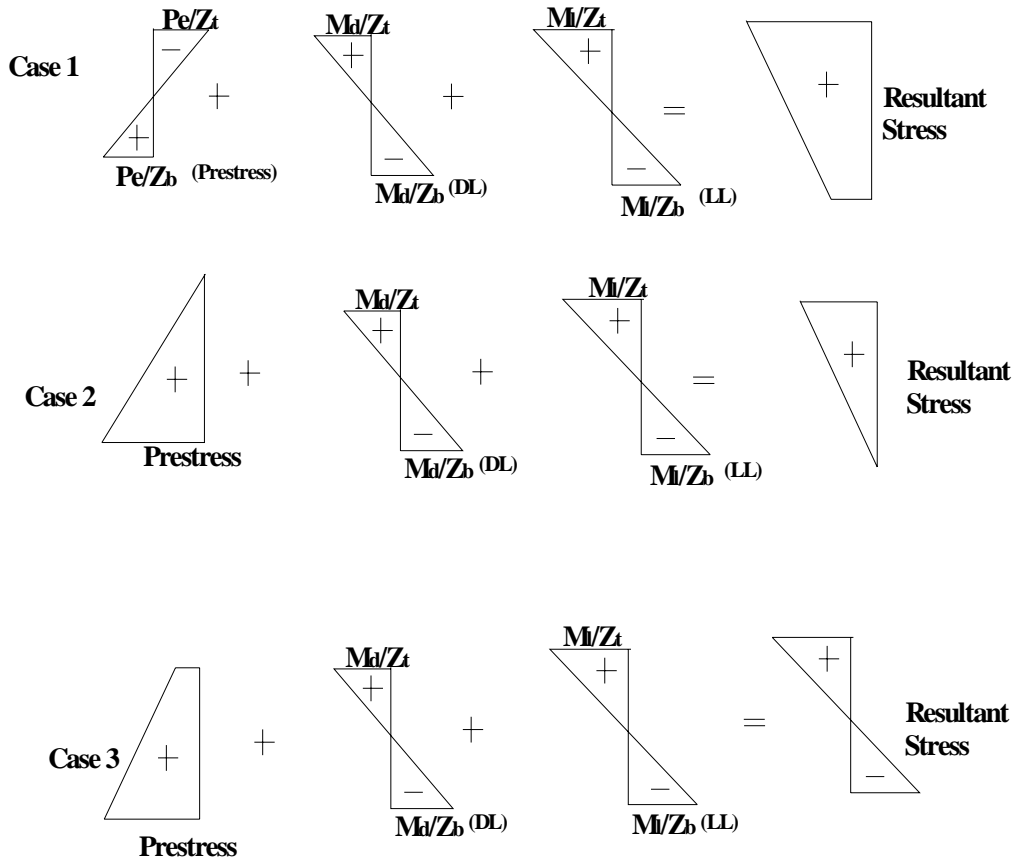

**Example**

A rectangular concrete beam of cross-section 30 cm deep and 20 cm wide is prestressed by means of 15 wires of 5 mm diameter located 6.5 cm from the bottom of the beam and 3 wires of diameter of 5 mm, 2.5 cm from the top. Assuming the prestress in the steel as  $840 \text{ N/mm}^2$ , calculate the stresses at the extreme fibers of the mid-span section when the beam is supporting its own weight over a span of 6 m. If a uniformly distributed live load of  $6 \text{ kN/m}$  is imposed, evaluate the maximum working stress in concrete. The density of concrete is  $24 \text{ kN/m}^3$ .

**Solution:-**

Data Provided:

Cross section of beam:  $30 \text{ cm} \times 20 \text{ cm}$

Prestressed by ; 15 no. 5 mm diameter wires (6.5 cm from bottom)

3 no. 5mm diameter wires (2.5 cm from top)

Prestress in steel: 840 N/mm<sup>2</sup>  
 Span of the beam: 6 m  
 Density of concrete: 24 kN/mm<sup>2</sup>

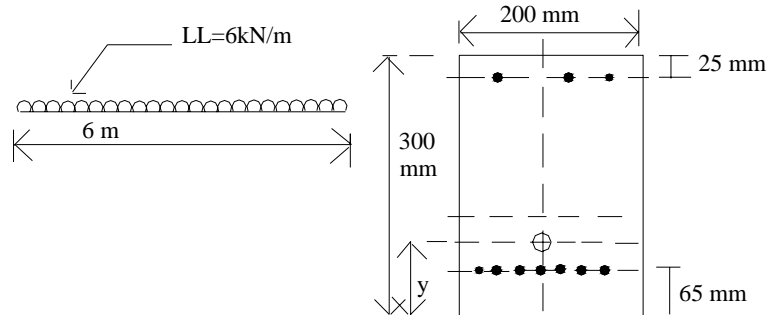

Distance of the centroid of prestressing force from the base

$$y = \left( \frac{(15 \times 65) + (3 \times 275)}{18} \right) = 100 \text{ mm}$$

Eccentricity,  $e = 150 - 100 = 50 \text{ mm}$

Prestressing force,  $P = (840 \times 18 \times 19.7) = 3 \times 10^5 \text{ N}$

Area of concrete section,  $A = (300 \times 200) = 45 \times 10^5 \text{ mm}^2$

Second moment of area,  $I = 200 \times 300^3 / 12 = 45 \times 10^7 \text{ mm}^4$

Section modulus ( $Z_t$  &  $Z_b$ ) =  $(45 \times 10^7 / 150) = 3 \times 10^6 \text{ mm}^3$

Self weight of the beam =  $(0.2 \times 0.3 \times 24) = 1.44 \text{ kN/m}$

Moment due to self weight,  $M_d = \left( \frac{1.44 \times 6^2}{8} \right) = 6.48 \text{ kNm}$

Live load Moment  $M_l = \left( \frac{6 \times 6^2}{8} \right) = 27 \text{ kNm}$

Direct stress due to prestress  $\left( \frac{P}{A} \right) = \left( \frac{3 \times 10^5}{6 \times 10^4} \right) = 5 \text{ N/mm}^2$

Bending stress due to prestress  $\left( \frac{Pe}{Z} \right) = \left( \frac{3 \times 10^5 \times 50}{3 \times 10^6} \right) = 5 \text{ N/mm}^2$

Self weight stress,  $M_d / Z = \left( \frac{6.48 \times 10^6}{3 \times 10^6} \right) = 2.16 \text{ N/mm}^2$

Live load stress  $M_l / Z = \left( \frac{27 \times 10^6}{3 \times 10^6} \right) = 9 \text{ N/mm}^2$

The resultant working stresses due to (self weight + prestress + LL) in the concrete =  $11.16 \text{ N/mm}^2$  (compressive) and  $1.16 \text{ N/mm}^2$  (tensile)

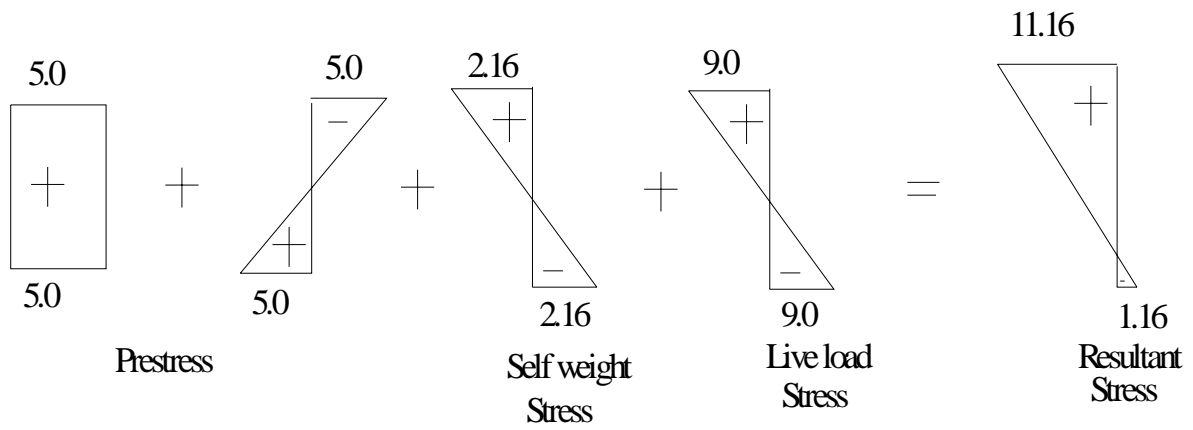

Dr. D. Maity, III

## Lecture Note – 19

### Losses in Prestress -I

The initial prestressing concrete undergoes a gradual reduction with time from the stages of transfer due to various causes. This is generally defined as total “Loss of Prestress”. The various losses are explained below:

#### **Types of losses in prestress**

##### Pretensioning

1. Elastic deformation of concrete
2. Relaxation of stress in steel
3. Shrinkage of concrete
4. Creep of concrete

##### Post-tensioning

1. No loss due to elastic deformation if all wires are simultaneously tensioned. If the wires are successively tensioned, there will be loss of prestress due to elastic deformation of concrete.
2. Relaxation of stress in steel
3. Shrinkage of concrete
4. Creep of concrete
5. Friction
6. Anchorage slip

#### **Loss due to elastic deformation of the concrete**

The loss of prestress due to deformation of concrete depends on the modular ratio & the average stress in concrete at the level of steel.

If

$f_c \rightarrow$  Prestress in concrete at the level of steel

$E_s \rightarrow$  Modulus of elasticity of steel

$E_c \rightarrow$  Modulus of elasticity of concrete

$\alpha_e \rightarrow$  Modular ratio

Strain in concrete at the level of steel =  $\frac{f_c}{E_c}$

Stress in steel corresponding to this strain =  $\frac{f_c}{E_c} E_s$

Therefore, Loss of stress in steel =  $\alpha_e f_c$

If the initial stress in steel is known, the percentage loss of stress in steel due to elastic deformation of concrete can be computed.

### Example 1: (Elastic deformation)

A pre-stressed concrete beam, 100 mm wide and 300 mm deep, is pre-tensioned by straight, wires carrying an initial force of 150kN at an eccentricity of 50 mm. The modulus of elasticity of steel and concrete are 210 and 35 kN/mm<sup>2</sup> respectively. Estimate the percentage loss of stress in steel due to elastic deformation of concrete if the area of steel wires is 188 mm<sup>2</sup>.

#### Solution:

Here,

Force,  $P = 150 \text{ kN}$  ; Eccentricity,  $e = 50 \text{ mm}$

Area of concrete section,  $A = (100 \times 300) = 3 \times 10^4 \text{ mm}^2$

Area of the steel wire = 188 mm<sup>2</sup>

Section modulus,  $I = 225 \times 10^6 \text{ mm}^4$

$$\text{Modular ratio, } \alpha_e = \left( \frac{E_s}{E_c} \right) = 6$$

$$f_c = \frac{P}{A} + \left( \frac{P}{A} + \frac{Pe}{Z_b} \right)$$

$$\text{Initial stress in steel} = \left( \frac{150 \times 10^3}{188} \right) = 800 \text{ N/mm}^2$$

$$\text{Stress in concrete, } f_c = \left( \frac{150 \times 10^3}{3 \times 10^4} \right) + \left( \frac{150 \times 10^3 \times 50 \times 50}{225 \times 10^6} \right) = 6.66 \text{ N/mm}^2$$

$$\text{Loss of stress due to elastic deformation of concrete} = \alpha_e f_c = (6 \times 6.66) = 40 \text{ N/mm}^2$$

$$\text{Percentage loss of stress in steel} = \left( \frac{40 \times 100}{800} \right) = 5\%$$

### Loss due to shrinkage of concrete

#### Factors affecting the shrinkage in concrete

1. The loss due to shrinkage of concrete results in shortening of tensioned wires & hence contributes to the loss of stress.
2. The shrinkage of concrete is influenced by the type of cement, aggregate & the method of curing used.
3. Use of high strength concrete with low water cement ratio results in reduction in shrinkage and consequent loss of prestress.



4. The primary cause of drying shrinkage is the progressive loss of water from concrete.
5. The rate of shrinkage is higher at the surface of the member.
6. The differential shrinkage between the interior surfaces of large member may result in strain gradients leading to surface cracking.

Hence, proper curing is essential to prevent cracks due to shrinkage in prestress members. In the case of pretensioned members, generally moist curing is restored in order to prevent shrinkage until the time of transfer. Consequently, the total residual shrinkage strain will be larger in pretensioned members after transfer of prestress in comparison with post-tensioned members, where a portion of shrinkage will have already taken place by the time of transfer of stress. This aspect has been considered in the recommendation made by the code (IS:1343) for the loss of prestress due to shrinkage of concrete and is obtained below:

If

$$\begin{aligned} \varepsilon_{cs} \rightarrow \text{Total residual shrinkage strain} &= 300 \times 10^{-6} \text{ for pre-tensioning and} \\ &= \left[ \frac{200 \times 10^{-6}}{\log_{10}(t+2)} \right] \text{ for post-tensioning.} \end{aligned}$$

Where,

$t \rightarrow$  Age of concrete at transfer in days.

Then, the loss of stress =  $\varepsilon_{cs} E_s$

Here,  $E_s \rightarrow$  Modulus of elasticity of steel

### Example 2: (Shrinkage)

A concrete beam is pre-stressed by a cable carrying an initial pre-stressing force of 300kN. The cross-sectional area of the wires in the cable is 300 mm<sup>2</sup>. Calculate the percentage loss of stress in the cable only due to shrinkage of concrete using IS: 1343 recommendations assuming the beam to be, (a) pre-tensioned and (b) post-tensioned. Assume  $E_s = 210 \text{ kN/mm}^2$  and age of concrete at transfer = 8 days.

### Solution:

$$\text{Initial stress in wires} = \left( \frac{300 \times 10^3}{300} \right) = 1000 \text{ N/mm}^2$$

(a) If the beam is pre-tensioned, the total residual shrinkage strain =  $300 \times 10^{-6}$  units

$$\therefore \text{Loss of stress} = \varepsilon_{cs} \cdot E_s = (300 \times 10^{-6})(210 \times 10^3) = 63 \text{ N/mm}^2$$

$$\text{Percentage loss of stress} = \left( \frac{63}{1000} \times 100 \right) = 6.3\%$$

(b) If the beam is post-tensioned, the total residual shrinkage strain

$$\varepsilon_{cs} = \left( \frac{200 \times 10^{-6}}{\log_{10}(t+2)} \right) = \left( \frac{200 \times 10^{-6}}{\log_{10}(8+2)} \right) = 200 \times 10^{-6} \text{ units}$$

$$\therefore \text{Loss of stress} = \varepsilon_{cs} \cdot E_s = (200 \times 10^{-6})(210 \times 10^3) = 42 \text{ N/mm}^2$$

$$\text{Percentage loss of stress} = \left( \frac{42}{1000} \times 100 \right) = 4.2\%$$

### Loss due to creep of concrete

The sustained prestress in the concrete of a prestress member results in creep of concrete which is effectively reduces the stress in high tensile steel. The loss of stress in steel due to creep of concrete can be estimated if the magnitude of ultimate creep strain or creep-coefficient is known.

#### 1. Ultimate Creep strain method

The loss of stress in steel due to creep of concrete =  $\varepsilon_{cc} f_c E_s$

Where,  $\varepsilon_{cc}$  → Ultimate creep strain for a sustained unit stress.

$f_c$  → Compressive stress in concrete at the level of steel

$E_s$  → Modulus of elasticity of steel

#### 2. Creep Coefficient Method

$$\text{Creep coefficient} = \frac{\text{Creep strain}}{\text{Elastic strain}} = \frac{\varepsilon_c}{\varepsilon_e}$$

$$\text{Therefore, loss of stress in steel} = \varepsilon_c E_s = \phi \varepsilon_e E_s = \phi \left( \frac{f_c}{E_c} \right) E_s = \phi f_c \alpha_e$$

Where,  $\phi$  → Creep Coefficient

$\varepsilon_c$  → Creep strain

$\varepsilon_e$  → Elastic strain

$\alpha_e$  → Modular ratio

$f_c$  → Stress in concrete

$E_c$  → Modulus of elasticity of concrete

$E_s$  → Modulus of elasticity of steel

The magnitude of creep coefficient varies depending upon the humidity, concrete quality, duration of applied loading and the age of concrete when loaded. The general value recommended varies from 1.5 for watery situation to 4.0 for dry conditions with a relative humidity of 35%.

### Example 3: (Creep)

A concrete beam of rectangular section, 100 mm wide and 300 mm deep, is pre-stressed by five wires of 7 mm diameter located at an eccentricity of 50 mm, the initial stress in the wires being  $1200 \text{ N/mm}^2$ . Estimate the percentage loss of stress in steel due to creep of concrete using the ultimate creep strain method and the creep coefficient method (IS: 1343-1980). Use the following data:

**Solution:** Here,

$$E_s = 210 \text{ kN/mm}^2; E_c = 35 \text{ kN/mm}^2; I = 225 \times 10^6 \text{ mm}^4;$$

$$\text{Ultimate creep strain } \varepsilon_{cc} = 41 \times 10^{-6} \text{ mm/mm per N/mm}^2$$

$$\text{Creep coefficient } (\phi) = 1.6;$$

$$\text{Prestressing force, } P = (5 \times 38.5 \times 1200) = 23 \times 10^4 \text{ N}$$

$$\text{Area of concrete section, } A = 300 \times 100 = 3 \times 10^4 \text{ mm}^2$$

$$\text{Modular ratio, } \alpha_e = \left( \frac{E_s}{E_c} \right) = 6$$

Stress in concrete at the level of steel is given by

$$f_c = \left[ \frac{23 \times 10^4}{3 \times 10^4} + \left( \frac{23 \times 10^4 \times 50 \times 50}{225 \times 10^6} \right) \right] = 10.2 \text{ N/mm}^2$$

#### Ultimate Creep Strain Method

$$\therefore \text{ Loss of stress in steel} = \varepsilon_{cc} \cdot f_c \cdot E_s = (41 \times 10^{-6})(10.2)(210 \times 10^3) = 88 \text{ N/mm}^2$$

Creep Coefficient Method

$$\therefore \text{ Loss of stress in steel} = \phi \cdot f_c \cdot \alpha_e = (1.6 \times 10.2 \times 6) = 97.92 \text{ N/mm}^2$$

## Lecture Note – 20

### Losses in Prestress -II

#### Loss due to relaxation of stress in steel

Most of the codes provide for the loss of stress due to relaxation of steel as a percentage of initial stress in steel. The BIS recommends a value varying from 0 to 90 N/mm<sup>2</sup> for stress in wires varying from  $0.5f_{pu}$  to  $0.8f_{pu}$

Where,  $f_{pu} \rightarrow$  Characteristic strength of pre-stressing tendon.

#### Loss of stress due to friction

The magnitude of loss of stress due to friction is of following types: -

- a. Loss due to curvature effect, which depends upon the tendon form or alignment, which generally follows a curved profile along the length of the beam.
- b. Loss of stress due to wobble effect, which depends upon the local deviations in the alignment of the cable. The wobble or wave effect is the result of accidental or unavoidable misalignment, since ducts or sheaths cannot be perfectly located to follow a predetermined profile throughout the length of beam.

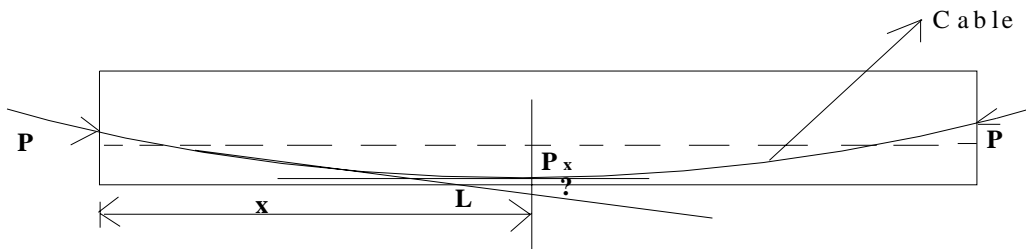

$$P_x = P_o e^{-(\mu\alpha+kx)}$$

Where,

$P_o \rightarrow$  The Prestressing force at the jacking end.

$\mu \rightarrow$  Coefficient of friction between cable and duct

$\alpha \rightarrow$  The cumulative angle in radians through the tangent to the cable profile has turned between any two points under consideration.

$k \rightarrow$  Friction coefficient for wave effect.

The IS code recommends the following value for  $k$

$k = 0.15$  per 100 m for normal condition

$= 1.5$  per 100 m for thin walled ducts where heavy vibration are encountered and in other adverse conditions.

#### Example 4 (friction)

A concrete beam of 10 m span, 100 mm wide and 300 mm deep, is pre-stressed by 3 cables. The area of each cable is  $200 \text{ mm}^2$  and the initial stress in the cable is  $1200 \text{ N/mm}^2$ . Cable 1 is parabolic with an eccentricity of 50 mm above the centroid at the supports and 50 mm below at the center of span. Cable 2 is also parabolic with zero eccentricity at supports and 50 mm below the centroid at the center of span. Cable 3 is straight with uniform eccentricity of 50 mm below the centroid. If the cables are tensioned from one end only, estimate the percentage loss of stress in each cable due to friction. Assume  $\mu = 0.35$  and  $k = 0.015$  per m.

Equation of parabola is given by:  $y = \left(\frac{4e}{L^2}\right)(L-x)$

Slope at ends (at  $x = 0$ ) =  $\frac{dy}{dx} = \left(\frac{4e}{L^2}\right)(L-2x) = \left(\frac{4e}{L}\right)$

#### Solution:

Here, Given Equation of parabola:  $y = \left(\frac{4e}{L^2}\right)(L-x)$

Slope at ends (at  $x = 0$ ) =  $\frac{dy}{dx} = \left(\frac{4e}{L^2}\right)(L-2x) = \left(\frac{4e}{L}\right)$

#### For cable 1

$e = 100 \text{ mm}$

Slope at end =  $\left(\frac{4 \times 100}{10 \times 1000}\right) = 0.04$

$\therefore$  Cumulative angle between tangents,  $\alpha = 2 \times 0.04 = 0.08$  radians

#### For cable 2

$e = 50 \text{ mm}$

Slope at end  $\left(\frac{4 \times 50}{10 \times 1000}\right) = 0.02$

$\therefore$  Cumulative angle between tangents,  $\alpha = 2 \times 0.02 = 0.04$  radians

Initial pre-stressing force in each cable,  $P_0 = (200 \times 1200) = 24,0000 \text{ N}$

If  $P_x$  = pre-stressing force (stress) in the cable at the farther end,  $P_x = P_0 e^{-(\mu\alpha + kx)}$

For small values of  $(\mu\alpha + kx)$ , we can write

$$P_x = P_0 [1 - (\mu\alpha + kx)]$$

$$\text{Loss of stress} = P_0 (\mu\alpha + kx)$$

$$\text{Cable 1} = P_0 (0.35 \times 0.08 + 0.0015 \times 10) = 0.043P_0$$

$$\text{Cable 2} = P_0 (0.35 \times 0.04 + 0.0015 \times 10) = 0.029P_0$$

$$\text{Cable 3} = P_0 (0 + 0.0015 \times 10) = 0.015P_0$$

If  $P_0$  = Initial stress = 1200 N/mm<sup>2</sup>

Cable No	Loss of stress, kN/mm <sup>2</sup>	Percentage loss
1	51.6	4.3
2	34.8	2.9
3	18.0	1.5

### Loss due to Anchorage slip

The magnitude of loss of stress due to the slip in anchorage is computed as follows: -

If  $\Delta$  → Slip of anchorage, in mm

$L$  → Length of the cable, in mm

$A$  → Cross-sectional area of the cable in mm<sup>2</sup>

$E_s$  → Modulus of elasticity of steel in N/mm<sup>2</sup>

$P$  → Prestressing force in the cable, in N

$$\text{Then, } \Delta = \frac{PL}{AE_s}$$

$$\text{Hence, Loss of stress due to anchorage slip} = \frac{P}{A} = \frac{E_s \Delta}{L};$$

### Example 5:(Anchorage slip)

A concrete beam is post-tensioned by a cable carrying an initial stress of 1000 N/mm<sup>2</sup>. The slip at the jacking end was observed to be 5 mm. The modulus of elasticity of steel is 210 kN/mm<sup>2</sup>. Estimate the percentage loss of stress due to anchorage slip if the length of the beam is 30 m.

**Solution:**

$$\therefore \text{ Loss of stress due to anchorage slip} = \left( \frac{E_s \Delta}{L} \right)$$

$$= \frac{(210 \times 10^3)(5)}{30 \times 1000} = 35 \text{ N/mm}^2$$

$$\text{Percentage loss of stress} = \frac{35}{1000} \times 100 = 3.5\%$$

Since the loss is caused by a definite total amount of shortening, the percentage loss is higher for short members than for long members.

### Total losses allowed for in a design

It is a normal practice in the design of prestressed concrete members to assume the total loss of stress as a percentage of the initial stress & provide for this in the design computation. Since the loss of prestress depends on several factors it is difficult to generalize the exact amount of total loss of prestress. However, typical values of the total losses of the stress that could be encountered under normal conditions of work are recommended as follows:

The typical values for losses are as follows:-

Type of loss	Percentage loss of stress	
	Pre-tensioning	Post-tensioning
Elastic shortening & bending of concrete	4	1
Creep of concrete	6	5
Shrinkage of concrete	7	6
Creep in steel	8	8
Total	25	20

In this recommendation, it is assumed that temporary over stressing is done to reduce relaxation, and to compensate for friction and anchorage losses.

If

$f_{pe}$  → Effective stress in tendons after loss

$f_{pi}$  → Stress in tendon at transfer

$\eta$  → Reduction factor for loss of prestress

$$\text{Then, } \eta = \frac{f_{pe}}{f_{pi}};$$

$\eta = 0.75$  for pretensioned members

$= 0.80$  for post-tensioned member

## Lecture Note – 21

### Pressure line or thrust line

In prestress, the combined effect of prestressing force & external load can be resolved into a single force. The locus of the points of application of this force in any structure is termed as the pressure line or thrust line. The load here is such that stress at top fiber of support & bottom fiber of the central span is zero.

Let us consider a beam which is prestressed by a force  $P$  at a constant eccentricity  $e$ . The magnitude of load & eccentricity is such that the stress at the bottom fiber at the mid span is zero. It is possible if the eccentricity is  $e = d/6$  it can be seen from the resultant stress distribution at the support due to a prestressing force  $P$  at an eccentricity  $e = d/6$  & bending moment zero is equivalent to a force  $P$  applied at an eccentricity  $e = d/6$ . At quarter span the resultant stress distribution due force  $P$  applied at an eccentricity  $e = d/12$ . Similarly, at mid span the resultant stress distribution due to a force  $P$  at an eccentricity  $e = d/6$  & BM due to uniformly distributed load is equivalent to a force  $P$  applied at an eccentricity  $e = -d/6$ .

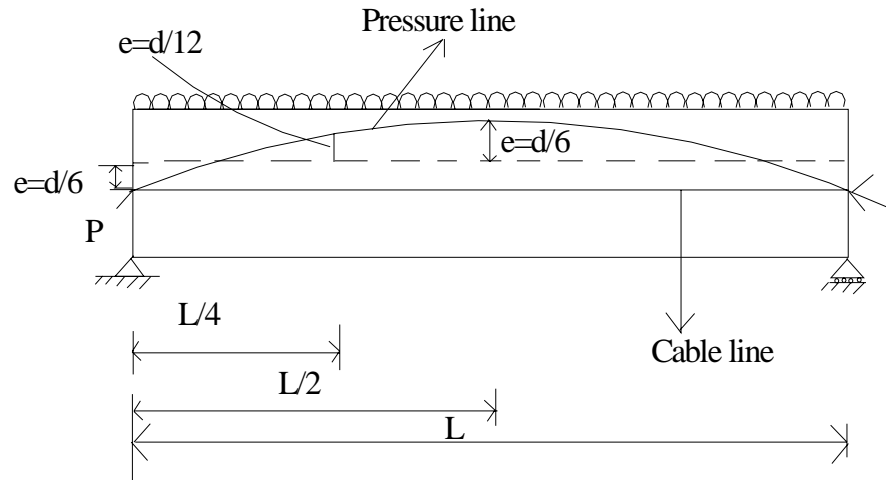

At support,  $x = 0$

$$\frac{P}{A} - \frac{M}{I} y = 0$$

$$\Rightarrow \frac{P}{bd} = \frac{P \cdot e \cdot \frac{d}{2}}{\frac{1}{12} bd^3}$$

$$\therefore e = \frac{d}{6}$$

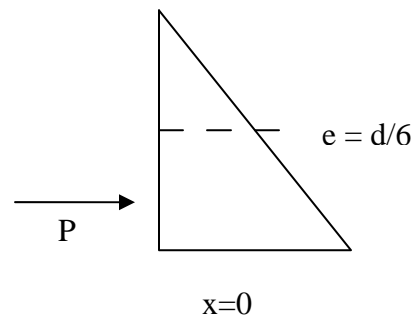



At mid span  $x = \frac{L}{2}$

Stress at the bottom is zero

$$\text{So, } \frac{P}{A} + \frac{M}{I} y = 0$$

$$\text{Hence, } e = -\frac{d}{6}$$

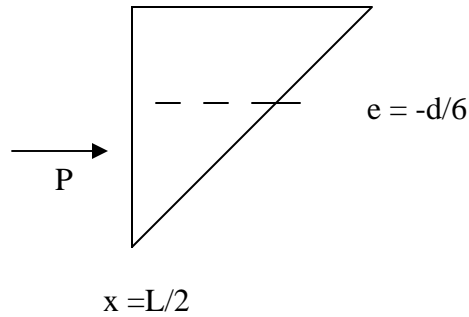

The negative sign in eccentricity indicates that it is measured above the central line. Thus, the pressure line has shifted from  $e = d/6$  at the support to  $e = -d/6$  at the mid span.

### Example:

A prestressed concrete beam with a rectangular section 120 mm wide by 300 mm deep supports a uniformly distributed load of 4 kN/m, which includes the self weight of the beam. The effective span of the beam is 6 m. The beam is concentrically prestressed by a cable carrying a force of 180 kN. Locate the position of the pressure line in the beam.

### Solution:-

Data Provided;

Dimensions of the prestressed concrete Beam = 120 mm × 300 mm

Effective span,  $l = 6\text{m}$

UDL,  $w = 4\text{ kN/m}$  (including self weight.)

Prestressing force  $P = 180\text{ kN}$

Eccentricity,  $e = 0$

Area,  $A = 36 \times 10^3\text{ mm}^2$

Section modulus,  $Z_t = Z_b = 18 \times 10^5\text{ mm}^3$

Bending moment at the center of span,  $M = (0.125 \times 4 \times 6^2) = 18\text{ kNm}$

$$\text{Direct stress (P/A)} = \frac{180 \times 10^3}{36 \times 10^3} = 5\text{ N/mm}^2$$

$$\text{Bending stress (M/Z)} = \frac{18 \times 10^6}{18 \times 10^5} = 10\text{ N/mm}^2$$

Resultant stresses;

$$\text{At top} = 10 + 5 = 15\text{ N/mm}^2 \text{ (compressive)}$$

$$\text{At bottom} = 5 - 10 = -5\text{ N/mm}^2 \text{ (tensile)}$$

If  $N =$  Resultant thrust in the section

$e =$  Corresponding eccentricity (shift of pressure line),

then  $N/A + Ne/Z = 15$

But,  $N = 180 \text{ kN}$ ,  $A = 36 \times 10^3 \text{ mm}^2$  and  $Z = 18 \times 10^5 \text{ mm}^3$

Solving the above equation,  $e = 100 \text{ mm}$ ;

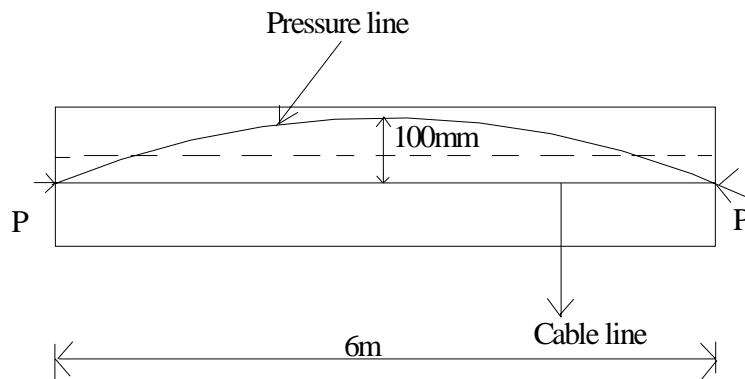
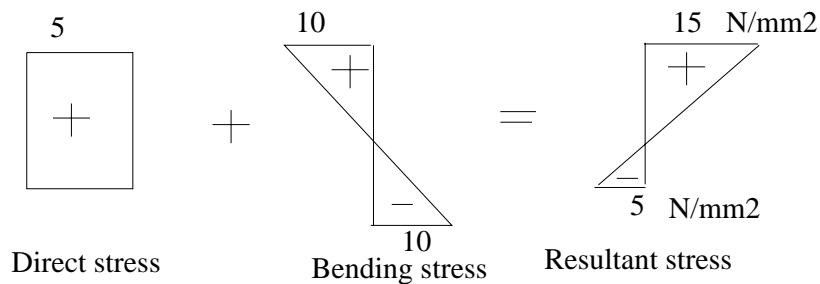

Fig. Location of pressure line in prestressed beam

**Example:-**

A prestressed concrete beam of section 120 mm wide by 300 mm deep is used over an effective span of 6 m to support a uniformly distributed load of 4 kN/m, which includes the self weight of the beam. The beam is prestressed by a straight cable carrying a force of 180 kN & located at an eccentricity of 50 mm. Determine the location of the thrust-line in the beam and plot its position at quarter and central span sections.

**Solution:-**

Here, Given  $P = 180 \text{ kN}$  ;  $e = 50 \text{ mm}$

$A = 36 \times 10^3 \text{ mm}^2$  ;  $Z = 18 \times 10^5 \text{ mm}^3$

At Central Span Section:

$$\text{Prestress due to direct stress } \left(\frac{P}{A}\right) = \left(\frac{180 \times 10^3}{36 \times 10^3}\right) = 5 \text{ N/mm}^2$$

$$\text{Prestress due to bending } \left(\frac{Pe}{Z}\right) = \left(\frac{180 \times 10^3 \times 50}{18 \times 10^5}\right) = 5 \text{ N/mm}^2$$

$$\text{BM at the centre} = 4 \times 6^2 / 8 = 18 \text{ kNm}$$

$$\text{Bending stresses at the top and bottom} = \pm \left(\frac{18 \times 10^6}{18 \times 10^5}\right) = \pm 10 \text{ N/mm}^2$$

Resultant stresses at the central section:

$$\text{At Top} = (5 - 5 + 10) = 10 \text{ N/mm}^2$$

$$\text{At bottom} = (5 + 5 - 10) = 0 \text{ N/mm}^2$$

$$\text{Shift of pressure line from cable line} = M/P = \left(\frac{18 \times 10^6}{18 \times 10^4}\right) = 100 \text{ mm}$$

At Quarter Span Section:

$$\text{BM at quarter span section} = (3/32) ql^2 = 13.5 \text{ kNm.}$$

$$\text{Bending stresses at the top and bottom} = \left(\frac{13.5 \times 10^6}{18 \times 10^4}\right) = 7.5 \text{ N/mm}^2$$

Resultant stresses at the quarter span section:

$$\text{At Top} = (5 - 5 + 7.5) = 7.5 \text{ N/mm}^2$$

$$\text{At bottom} = (5 + 5 - 7.5) = 2.5 \text{ N/mm}^2$$

$$\text{Shift of pressure line from cable line} = M/P = \left(\frac{13.5 \times 10^6}{18 \times 10^4}\right) = 75 \text{ mm}$$

The location of the pressure line is shown in the figure

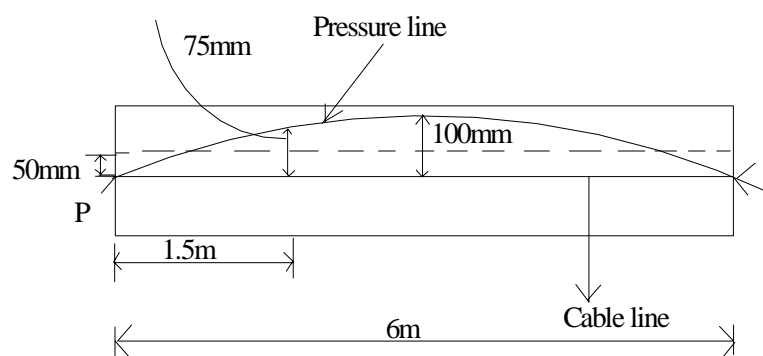

Fig. Location of pressure line in the prestressed concrete

**Example:-**

A rectangular concrete beam 250 mm wide by 300 mm deep is prestressed by a force of 540 kN at a constant eccentricity of 60 mm. The beam supports a concentrated load of 68 kN at the centre of the span of 3 m. Determine the location of the pressure line at the centre, quarter span and support sections of the beam. Neglect the self weight of the beam.

**Solution:-**

Here, Given

$$P = 540 \text{ kN}; A = (250 \times 300) = (375 \times 10^3) \text{ mm}^2; e = 60 \text{ mm}; Z = \frac{250 \times 300^2}{6} = 375 \times 10^4 \text{ mm}^3$$

$$\text{At the centre of the span } M_q = (0.25 \times 68 \times 3) = 51 \text{ kNm}$$

$$\text{At the quarter span } M_q = (0.125 \times 68 \times 3) = 25.5 \text{ kNm}$$

Stresses due to prestressing force:

$$\text{Prestress due to direct stress } \left( \frac{P}{A} \right) = \left( \frac{54 \times 10^4}{375 \times 10^3} \right) = 7.2 \text{ N/mm}^2$$

$$\text{Prestress due to bending } \left( \frac{Pe}{Z} \right) = \left( \frac{54 \times 10^4 \times 60}{375 \times 10^4} \right) = 8.6 \text{ N/mm}^2$$

Stresses due external loads

$$\text{At the centre of span } \left( \frac{M_q}{Z} \right) = \left( \frac{51 \times 10^6}{375 \times 10^4} \right) = 13.6 \text{ N/mm}^2$$

$$\text{At the quarter span } \left( \frac{M_q}{Z} \right) = \left( \frac{25.5 \times 10^6}{375 \times 10^4} \right) = 6.8 \text{ N/mm}^2$$

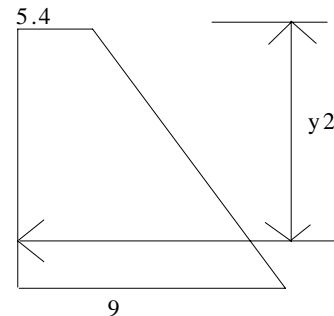
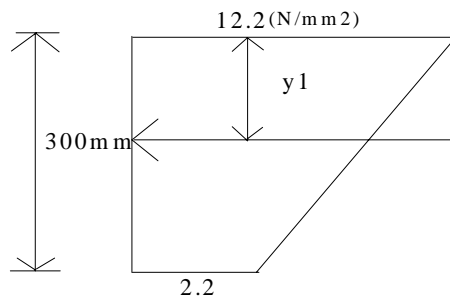

The position of the resultant thrust from the top fibre of the beam is as follows:

$$y_1 = \left[ \frac{(300 \times 2.2)150 + (1/2 \times 300 \times 10)100}{660 + 1500} \right] = 115 \text{ mm}$$

$$y_2 = \left[ \frac{(300 \times 5.4)150 + (1/2 \times 300 \times 3.6)200}{1620 + 540} \right] = 162 \text{ mm}$$

Thus, the location of the pressure line will be as follows:

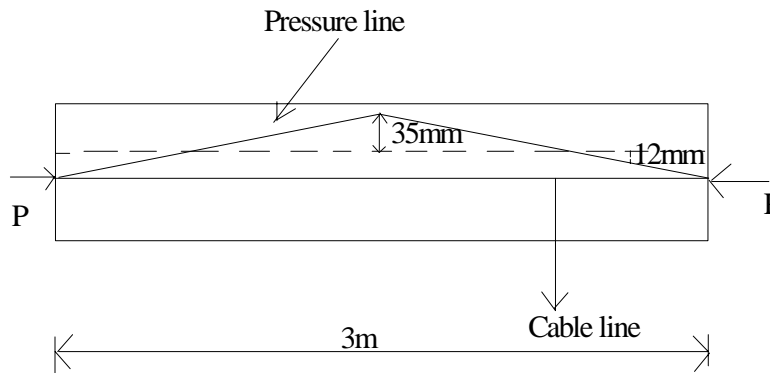

Fig. Location of pressure line in the prestressed concrete

Dr. D. Mani

## Lecture Note – 22

### Concept of load balancing

In the prestress concrete, it is possible to select cable profile in such a way that the transverse component of the cable force balances the given type of external loading.

If in a parabolic prestressing tendon

$e_{\max}$  → Maximum eccentricity

$P$  → Prestressing force

Then the prestressing force may be considered as an upward uniformly distributed load.

The maximum prestressing moment can be equated to the maximum BM due to upward uniformly distributed load on the beam. So



$$\frac{w_p l^2}{8} = P e_{\max}$$

$$\Rightarrow w_p = \frac{8 P e_{\max}}{l^2}$$

If  $w$  → The downward load

Then net load,  $w_0 = w - w_p$

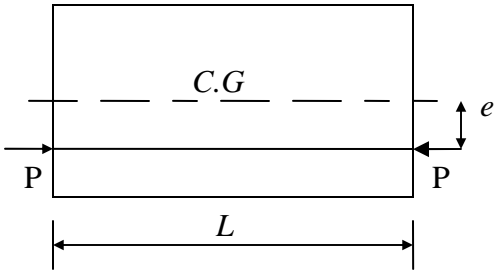
Net bending moment,  $M = -\frac{w_0 l^2}{8}$

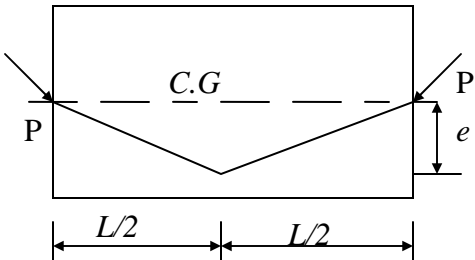
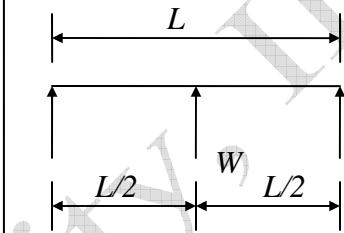
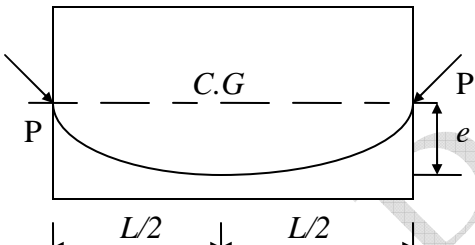
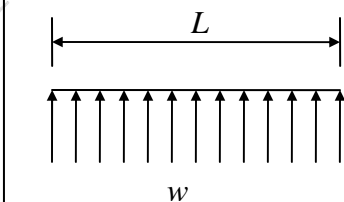
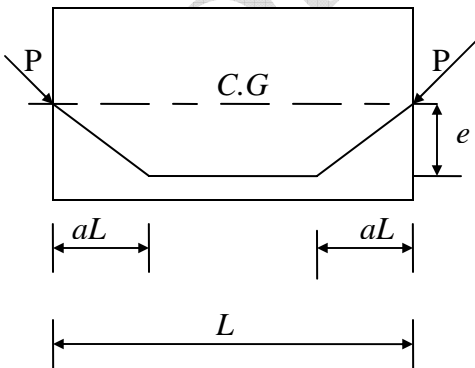
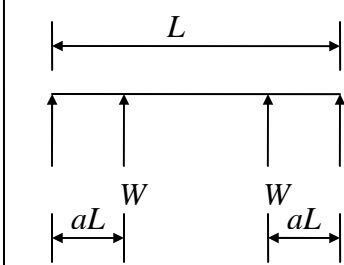
Tendon profile	Equivalent moment or Load	Equivalent loading	Camber
	$M = pe$		$\frac{ML^2}{8EI}$
	$W = \frac{4Pe}{L}$		$\frac{WL^3}{48EI}$
	$w = \frac{8Pe}{L^2}$		$\frac{5wL^4}{384EI}$
	$W = \frac{Pe}{aL}$		$\frac{a(3-4a^2)WL^3}{24EI}$

Example: (Load balancing concept)

A rectangular concrete beam 300 mm wide, 800 mm deep supports two concentrated loads of 20 kN each at third point of a span of 9 m.

- Suggest a suitable cable profile. If eccentricity of the cable profile is 100 mm for middle third portion of the beam, calculate the prestressing force required to balance the bending effect of the concentrated loads neglecting the self weight.
- For the same cable profile find effective force in cable if the resultant stress due to self wt., imposed load, and prestressing force is zero at the bottom fiber of mid span section. (Assume density of concrete = 24 kN/m<sup>3</sup>)

**Solution:-**

Here given section = 300 mm × 800 mm; Span ( $L$ ) = 9 m

**For (a)**

A trapezoidal cable profile is selected since the bending moment diagram is trapezoidal in shape.

$$e = 100 \text{ mm};$$

$$Pe = \left( \frac{QL}{3} \right)$$

$$\therefore P = \left( \frac{QL}{3e} \right) = \left( \frac{20 \times 9000}{3 \times 100} \right) = 600 \text{ kN}$$

**For (b)**

Self wt of beam,  $g = (0.3 \times 0.8 \times 24) = 5.76 \text{ kN/m}$

Self wt moment,  $M_g = (0.125 \times 5.76 \times 9^2) = 58.32 \text{ kNm}$

$$\text{Bending stress} = \left( \frac{58.32 \times 10^6}{32 \times 10^6} \right) = 1.82 \text{ N/mm}^2$$

$$\text{Moment at the center due to the loads} = \left( \frac{QL}{3} \right) = \left( \frac{20 \times 9}{3} \right) = 60 \text{ kNm}$$

$$\text{Stresses due to loads} = \left( \frac{60 \times 10^6}{32 \times 10^6} \right) = 1.875 \text{ N/mm}^2$$

Total tensile bending stress at the bottom fiber = 1.82 + 1.875 = 3.695 N/mm<sup>2</sup>

Let,  $P$  be required prestressing force in cable,

$e = 100 \text{ mm}$ , Area of the concrete section,  $A = 300 \times 800 = 24 \times 10^4 \text{ mm}^2$

$$\text{Thus, } \frac{P}{A} + \frac{Pe}{Z} = 3.695 \quad \therefore P = 507 \text{ kN.}$$

**Example:- (Concrete beam with over hang)**



A concrete beam with a single overhang is simply supported at A & B over a span of 8 m & the overhang BC is 2 m. The beam is of rectangular section 300 mm wide 900 mm deep & supports a uniformly distributed live load of 3.52 kN/m over the entire length in addition to its self-weight. Determine the profile of the prestressing cable with an effective force of 500 kN which can balance the dead & live loads on the beam. Sketch the profile of the cable along the length of the beam. The single overhang beam ABC supporting the UDL is shown in the figure below.

**Solution:-**

Span = 8 m, overhang = 2 m. Section = 300 mm × 900 mm

Udl = 3.52 kN/m

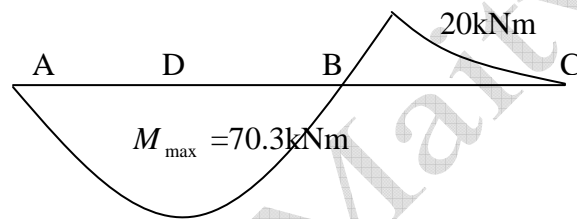
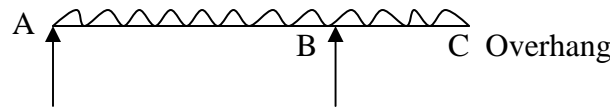

B.M.diagram

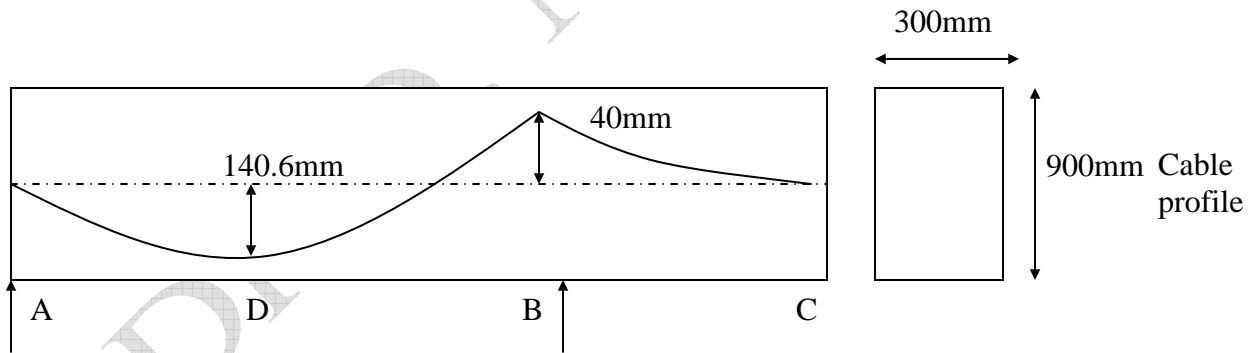

Prestressing force in the cable,  $P = 500 \text{ kN}$ .

Self weight of the beam =  $(0.3 \times 0.9 \times 24) = 6.48 \text{ kN/m}$

Live load on the beam =  $3.52 \text{ kN/m}$

Thus, the total load =  $10.00 \text{ kN/m}$

Reactions at A and B are

$R_a = 37.5 \text{ kN}$ ;  $R_b = 62.5 \text{ kN}$

$$M_b = 0.5 \times 10 \times 2^2 = 20 \text{ kNm}$$

Bending moment at a distance  $x$  from a is

$$M_x = 37.5 \times x - 0.5 \times 10 \times x^2$$

For maximum BM  $\frac{dM_x}{dx} = 0 \Rightarrow 37.5 - 10x = 0$

$$x = 3.75 \text{ m}$$

Hence, maximum BM =  $37.5 \times 3.75 - 0.5 \times 10 \times 3.75^2 = 70.3 \text{ kNm}$

$$M_x = 0, \text{ at } x = 7.5 \text{ m [As, } 5x^2 - 37.5x = 0]$$

The eccentricity of the cable at the position of maximum BM is

$$e = \left( \frac{M_{\max}}{P} \right) = \frac{70.3 \times 10^6}{500 \times 10^3} = 140.6 \text{ mm}$$

Eccentricity at B,  $e_b = \left( \frac{M_b}{P} \right) = \frac{20 \times 10^6}{500 \times 10^3} = 40 \text{ mm}$

Since the bending moment at point A and C are zero, the cable is concentric at these points. The cable profile is parabolic with eccentricity of 140.6 mm below the centroidal axis at D and 40 mm above the centroidal axis at support section B.

### Example:-

A beam of symmetrical I-section spanning 8 m has a flange width of 150 mm & flange thickness of 80 mm respectively. The overall depth of the beam is 450 mm. Thickness of the web is 80 mm. The beam is prestressed by a parabolic cable with an eccentricity of 150 mm at the centre of the span & zero at the supports. The LL on the beam is 2.5 kN/m.

- Determine the effective force in the cable for balancing the DL & LL on the beams.
- Sketch the distribution of resultant stress at the centre of span section for the above case.
- Calculate the shift of the pressure line from the tendon-centre-line.

### Solution:-

The properties of the I-section are as follows:

Area of the section,  $A = 0.63 \text{ m}^2$

Moment of inertia,  $I = 1.553 \times 10^9 \text{ mm}^4$

Section modulus,  $Z = 6.9 \times 10^6 \text{ mm}^3$

Eccentricity,  $e = 150 \text{ mm}$

Span,  $L = 8 \text{ m}$

Live load,  $w_l = 2.5 \text{ kN/m}$

Dead load,  $w_d = 0.63 \times 25 = 1.57 \text{ kN/m}$  [Assuming unit weight of concrete as  $25 \text{ kN/m}^3$ ]

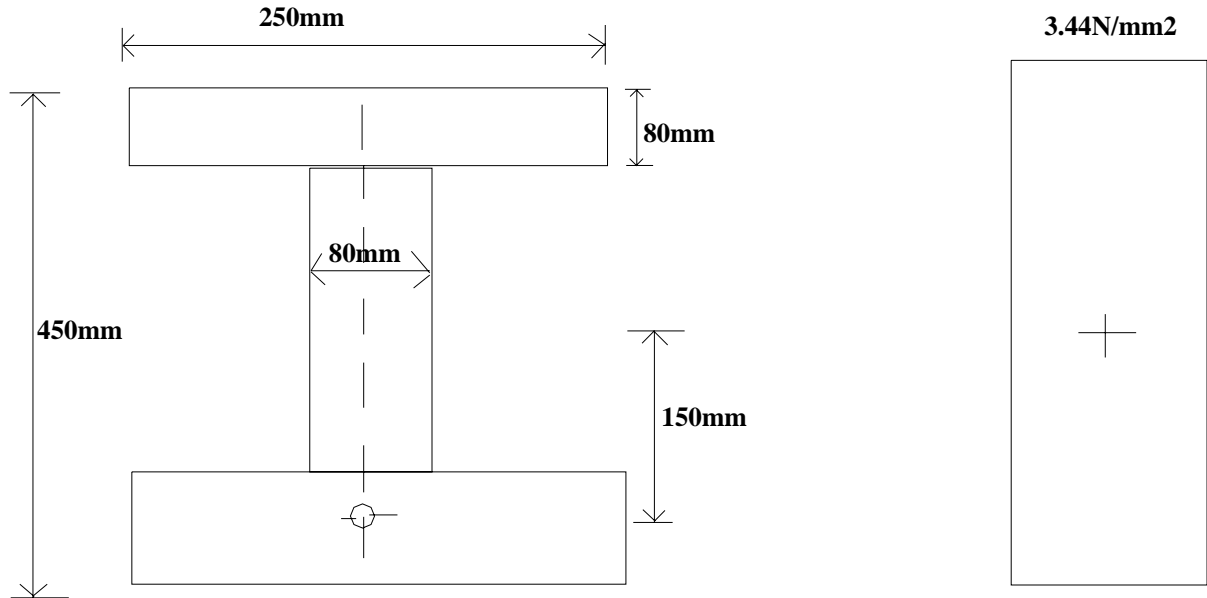

**Fig. Prestressed concrete beam of symmetrical I-section**

The BM at the centre of the span due to DL,  $M_d = (0.125 \times 1.57 \times 8^2) = 12.56 \text{ kN}$

The BM at the centre of the span due to LL,  $M_l = (0.125 \times 2.5 \times 8^2) = 20.00 \text{ kN}$

Therefore,

Total moment,  $M = (M_d + M_l) = 12.56 + 20 = 32.56 \text{ kN}$

If,  $P \rightarrow$  tendon force

For load balancing we have

$$P = \frac{M}{e} = \frac{32.56 \times 10^3}{150} = 217 \text{ kN}$$

The center-of-span section is subjected to a direct stress of intensity,

$$\left(\frac{P}{A}\right) = \frac{217 \times 10^3}{0.063 \times 10^6} = 3.44 \text{ N/mm}^2$$

$$\text{Shift of pressure line} = \frac{M}{P} = \frac{32.56 \times 10^6}{217 \times 10^3} = 150 \text{ mm}$$

The pressure line coincides with the centroidal axis of the beam

## Lecture Note – 23

### Deflections

#### Factors influencing deflection:

1. Imposed load & self load
2. Magnitude of prestressing force
3. Cable profile
4. Second moment of area of cross-section
5. Modulus of elasticity of concrete
6. Shrinkage, creep & relaxation of steel stress
7. Span of the member
8. Fixity condition

#### Short-term deflection of uncracked members

#### Mohr's theorem $\theta$

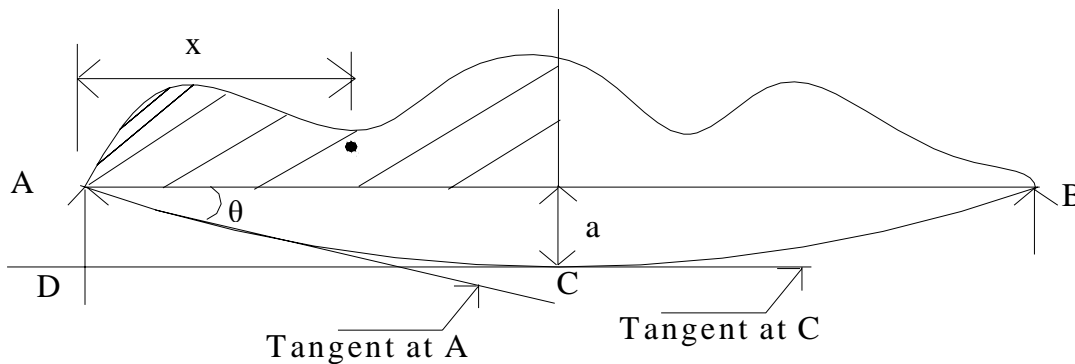

**Fig. Slope and deflection of beam**

- If  $\theta \rightarrow$  Slope of the elastic curve at A  
 $AD \rightarrow$  Intercept between the tangent at C & vertical at A  
 $a \rightarrow$  Deflection at the centre for symmetrically loaded simply supported beam  
 $A \rightarrow$  Area of the beam between A and C  
 $x \rightarrow$  Distance of the centroid of the BMD between A and C from the left support  
 $EI \rightarrow$  Flexural rigidity of the beam

Then by Mohr's first theorem

$$\text{Slope} = \frac{\text{Area of BMD}}{\text{Flexural rigidity}} ; \theta = \frac{A}{EI}$$

According to Mohr's second theorem

$$\text{Intercept, } a = \frac{\text{moment of area of BMD}}{\text{Flexural rigidity}} = \left( \frac{Ax}{EI} \right)$$

### Effect of tendon profile on deflection

#### 1. Straight tendon

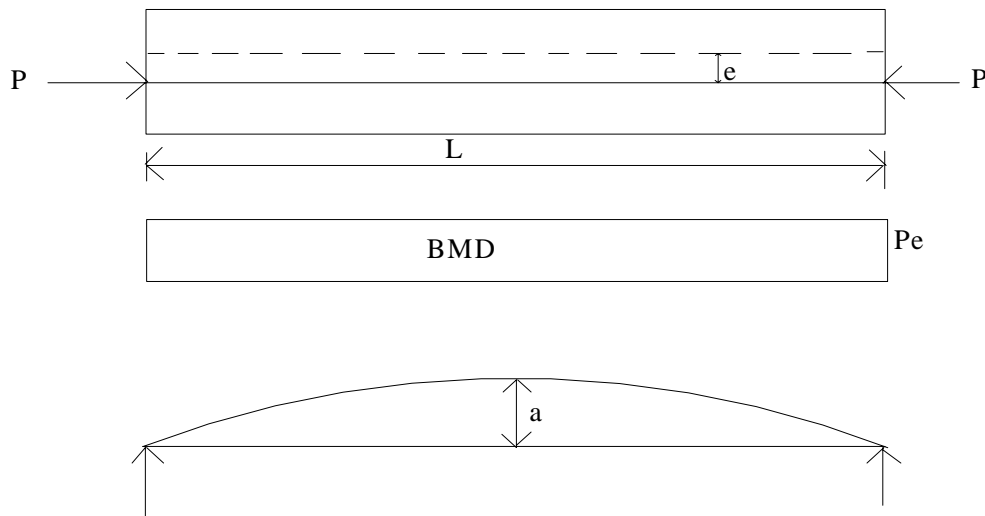

If  $P \rightarrow$  Effective prestressing force

$e \rightarrow$  Eccentricity

$L \rightarrow$  Length of the beam

Then,

$$\text{Deflection, } a = - \frac{\left( Pe \frac{L}{2} \right) \left( \frac{L}{4} \right)}{EI} = - \frac{PeL^2}{8EI}$$

### 2. Trapezoidal tendon

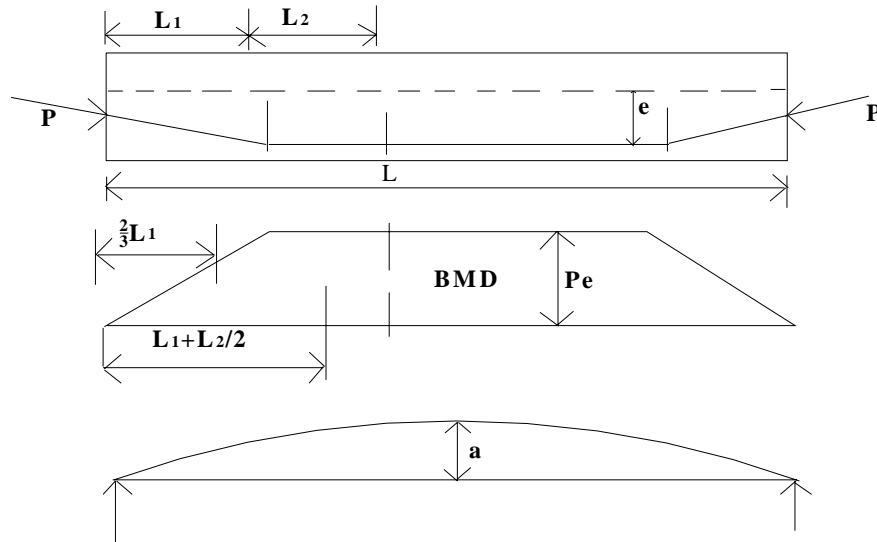

$$\text{Deflection, } a = \frac{Pe}{EI} \left[ l_2 \left( l_1 + l_2 / 2 \right) + \left( \frac{l_1}{2} \right) \left( \frac{2}{3l_1} \right) \right] = - \frac{PeL^2}{8EI} \left( 2l_1^2 + 6l_1l_2 + 3l_2^2 \right)$$

### 3. Parabolic tendons (Central Anchors)

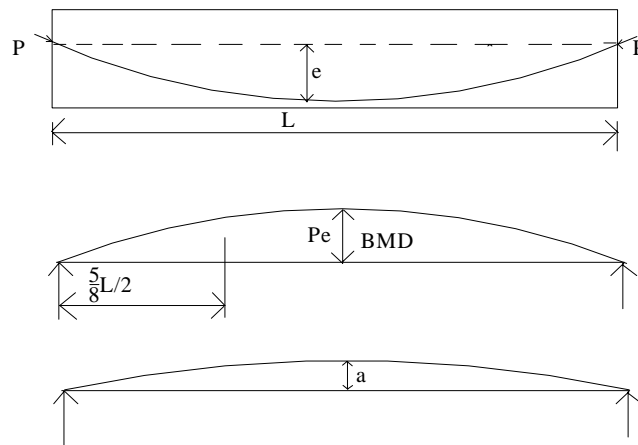

$$\text{Deflection, } a = \frac{Pe}{EI} \left[ \frac{2}{3} \cdot \frac{L}{2} \cdot \frac{5}{8} \cdot \frac{L}{2} \right] = - \left( \frac{5PeL^2}{48EI} \right)$$

**4. Parabolic tendons (Eccentric Anchors)**

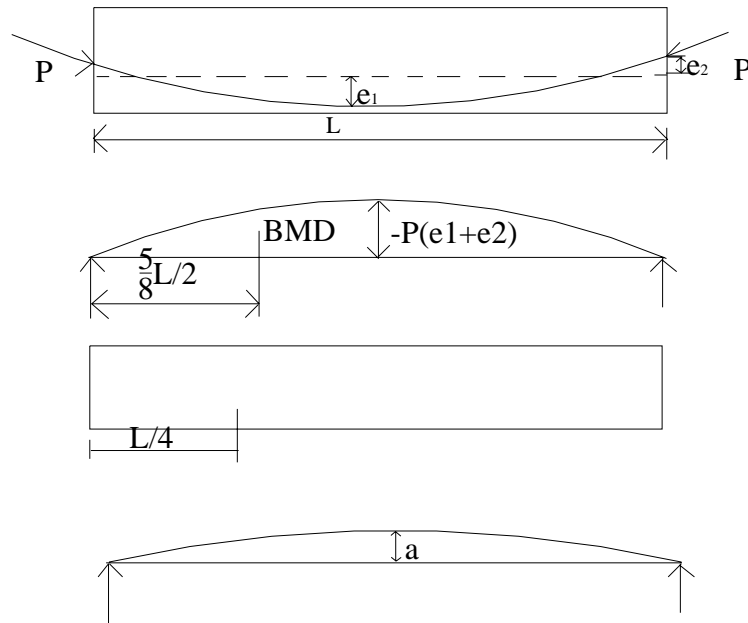

$$\text{Deflection, } a = \left[ \frac{-5 PL^2}{48 EI} (e_1 + e_2) \right] + \left[ \frac{Pe_2 L^2}{8EI} \right] = \frac{PL^2}{48EI} (-5e_1 + e_2)$$

**5. Sloping tendon (Eccentric Anchors)**

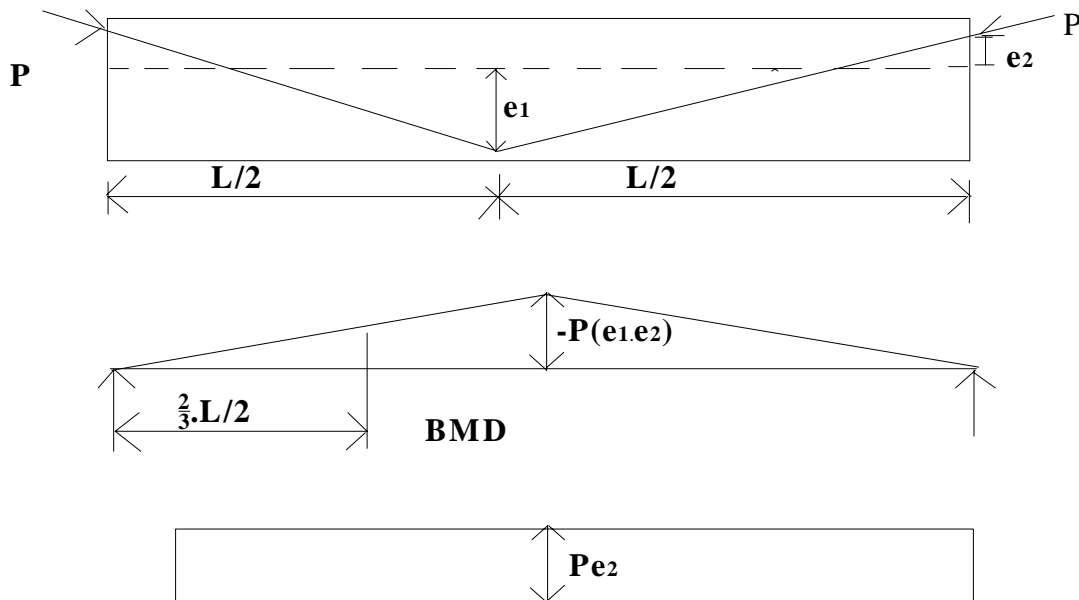

$$\text{Deflection, } a = \left[ -\frac{PL^2}{12EI} (e_1 + e_2) \right] + \left[ \frac{Pe_2 L^2}{8EI} \right] = \frac{PL^2}{24EI} (-2e_1 + e_2)$$

**6. Parabolic and straight Tendon**

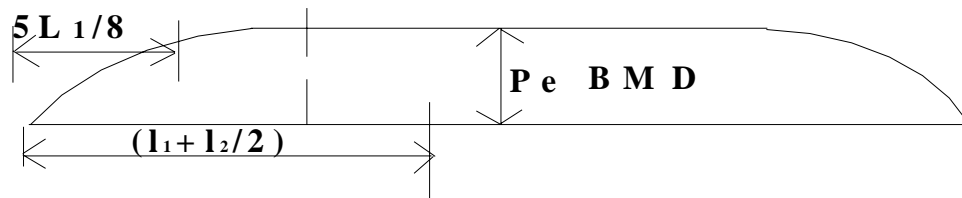
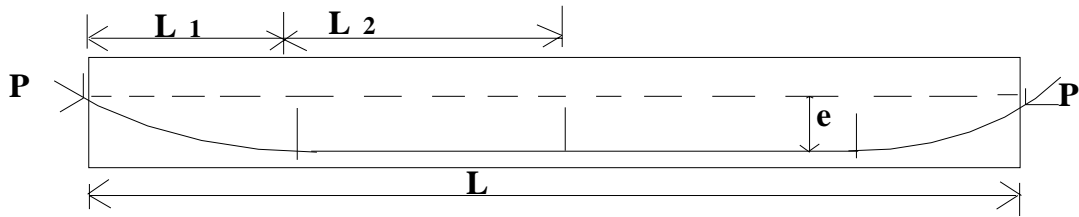

$$\text{Deflection, } a = \frac{Pe}{EI} \left[ \left( \frac{2l_1}{3} \right) \left( \frac{5l_1}{8} \right) + l_2 \left( l_1 + \frac{l_2}{2} \right) \right] = -\frac{Pe}{12EI} [5l_1^2 + 12l_1l_2 + 6l_2^2]$$

**7. Parabolic & straight tendons (Eccentric Anchors)**

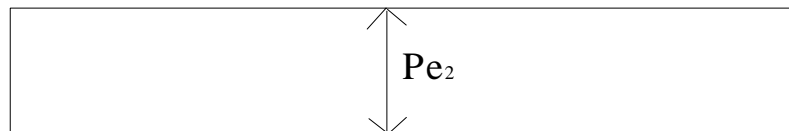
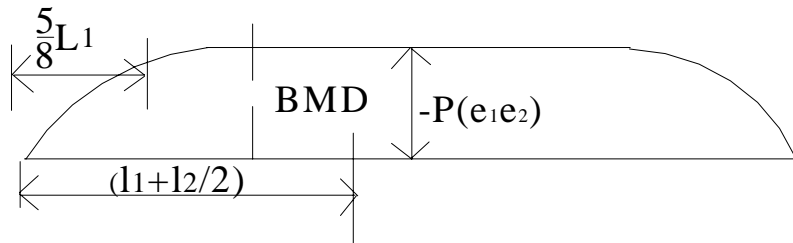
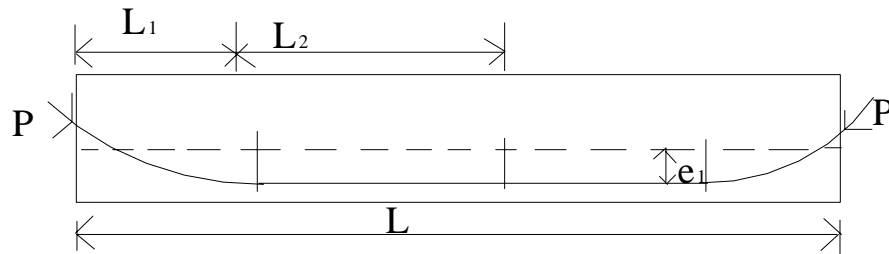

$$\text{Deflection, } a = -\frac{P(e_1 + e_2)}{12EI} [5l_1^2 + 12l_1l_2 + 6l_2^2] + \left[ \frac{Pe_2L^2}{8EI} \right]$$



**Load due to external loading**

If  $g \rightarrow$  Self weight of the beam per metre

$q \rightarrow$  Uniformly distributed superimposed load per metre

Then, Downward deflection,  $a = \frac{5(g+q)L^4}{384EI}$

**Example**

A concrete beam with cross-sectional area of  $32 \times 10^3 \text{ mm}^2$  & the radius of gyration is 72mm is prestressed by a parabolic cable carrying an effective stress of  $1000 \text{ N/mm}^2$ .

The span of the beam is 8 m. The cable, composed of 6 wires of 7mm diameter, has an eccentricity of 50mm at the centre & zero at the supports. Neglecting all losses, find the central deflection of the beam as follows:

- self-weight + prestress
- self-weight + prestress + live load of 2 kN/m.

**Solution: -**

Data Provided;

Cross sectional area of beam,  $A = 32 \times 10^3 \text{ mm}^2$

Modulus of elasticity,  $E = 38 \text{ kN/mm}^2$ ; Dead weight of concrete,  $D_c = 24 \text{ kN/mm}^3$ ;

Radius of gyration,  $i = 72 \text{ mm}$ ; Span,  $L = 8 \text{ m} = 8000 \text{ mm}$ ;

Eccentricity,  $e = 50 \text{ mm}$

$$I = Ai^2 = (32 \times 10^3 \times 72^2) = 166 \times 10^6 \text{ mm}^4$$

$$\text{Prestressing force, } P = (6 \times 38.5 \times 1000) = 231000 \text{ N} = 231 \text{ kN}$$

$$\text{Self weight, } g = \left( \frac{32 \times 10^3}{10^6} \times 24 \right) = 0.77 \text{ kN/m} = 0.00077 \text{ kN/mm}$$

$$\text{Downward deflection due to self weight} = \left( \frac{5gL^4}{384EI} \right) = \left( \frac{5 \times 0.00077 \times 8000^4}{384 \times 38 \times 166 \times 10^6} \right) = 6.5 \text{ mm}$$

$$\text{Upward deflection due to prestressing force} = \left( \frac{5PeL^4}{48EI} \right) = \left( \frac{5 \times 231 \times 50 \times 8000^4}{48 \times 38 \times 166 \times 10^6} \right) = 12.2 \text{ mm}$$

$$\text{Downward deflection due to live load} = \left( \frac{6.5}{0.77} \times 2 \right) = 16.9 \text{ mm}$$

$$(a) \text{ Deflection due to (self-weight + prestress)} = (12.2 - 6.5) = 5.7 \text{ mm}(\uparrow)$$

$$(b) \text{ Deflection due to (self-weight + prestress + live load)} = (6.5 - 12.2 + 16.9) = 11.2 \text{ mm}(\downarrow)$$